

Operating Instructions

PTFE Diaphragm Liquid Transfer Pump

Model: CG-1171-20



This is the safety alert symbol. It is used to alert you to potential personal injury hazards. Obey all safety messages that follow this symbol to avoid property damage, possible injury or death

You have selected a KNF Diaphragm Pump. The following tips will help you operate it safely and reliably over a long period. It is essential that you read these Operating Instructions before putting the pump into service. Follow them for all applications as they help prevent dangerous situations and damage to the pump and system.



■ Important Points

➔ User Instruction

① Operating Sequence

Table of Contents

<u>No</u>	<u>Section</u>	<u>Page</u>	<u>No</u>	<u>Section</u>	<u>Page</u>
1	Delivery Contents	2	7	Installation	4
2	Description	3	7.1	Installation	4
2.1	General Notes	3	7.2	Installing the Liquid Pump	4
2.2	Areas of Application	3	7.3	Operation	4
2.3	Features	3	7.4	Removing the Pump	4
2.4	Operating Principles	3	8	Error Messages	5
3	General Safety Instructions	3	8.1	Possible LED Error Messages	5
4	Transport and Storage	3	9	Troubleshooting	5
5	Setting Up	3	10	Technical Data	5
5.1	General Advice	3	10.1	LIQUIPORT®	5
5.2	Operating Conditions	3	10.2	CE-Marking	5
6	Pump and Controls	3	11	Exploded View	6
6.1	Pump	3	11.1	Spare Parts List	6
6.2	Controls	4	12	Return Request/Inquiries	6

1 Delivery Contents

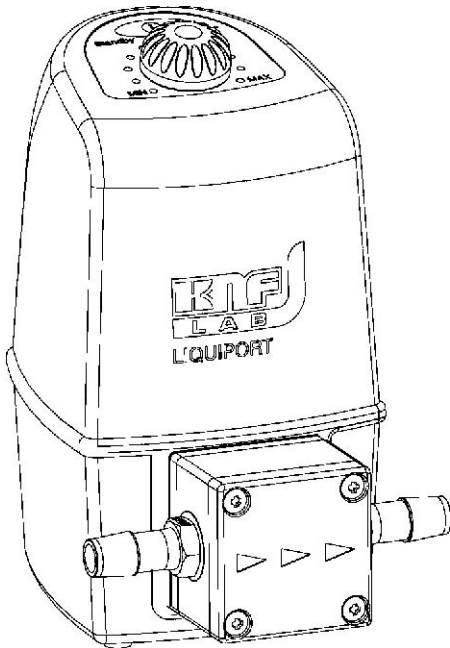

Pump

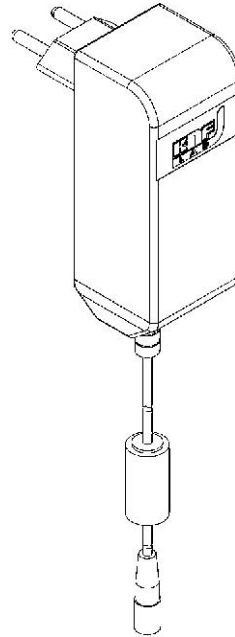

Power Adaptor

2 Description

2.1 General Notes

- It is essential that you read these Operating Instructions before putting the pump into service. Follow them for all applications as they help prevent dangerous situations and damage.
- The LIQUIPORT® diaphragm transfer pumps have been developed by KNF especially for laboratory and industrial applications that demand high chemical resistance, reliability and simple operation.

2.2 Areas of Application

Transfer of neutral and aggressive liquids in laboratories, industrial areas and systems.

2.3 Features of the LIQUIPORT®

- They are self-priming, can operate dry and are quiet.
- By using chemically resistant materials such as PTFE, PVDF, FPM etc. for parts that come into contact with the liquid, almost all neutral and aggressive liquids can be handled.
- Due to the compact construction it requires very little work surface.
- The flow can be adjusted manually on every model.
- Maintenance free.

2.4 Operating Principles

The LIQUIPORT® pump is an oscillating positive displacement pump. An eccentric converts the rotary motion of the drive shaft into an oscillating movement of a connecting rod, which in turn transmits its motion to the diaphragm. In combination with inlet and outlet valves, this diaphragm motion produces the pumping action.

3 General Safety Instructions



- Ensure the pump is only used for its intended purpose.
- The unit may not be used in areas in which there is a danger of explosion.
- Only connect the pump into fused sockets.
- Observe all relevant safety and accident prevention regulations.
- Before working on the pump, disconnect it from the power supply!
- Only qualified people may open the parts of the equipment that contain live parts.
- The Operating Instructions should always be kept readily available and near the equipment.
- When cleaning the unit, make sure that no liquid enters the housing.
- Use only genuine spare parts from KNF.
- If you return your KNF pump for repair, please state for what medium it has been used for, especially if this is very aggressive/dangerous.
- If the pump has been used for dangerous or highly aggressive media, it must be cleaned before being returned.

4 Transport and Storage

- When packing the pump, make sure that it is properly secured inside the package.
- The package must be strong enough to withstand any rough treatment it may receive during transport.

➔ Use original packaging

5 Setting Up

5.1 General advice

As you set the pump up please pay attention to the following points.

- Ensure that the pump is on a stable surface and is standing upright on its 4 rubber feet.
- The pump can be mounted from underneath with four screws.
- All special safety instructions for the liquid/gas being handled must be observed.
- The head materials, compression fittings and tubing must be resistant against the liquids being pumped.
- ❶ Check that the connections between the compression fittings and Teflon tubing are secure.

5.2 Operating Conditions

- Permissible ambient temperature +5 to +40°C.
- The presence of solids in the medium being handled may lead to faulty operation of the pump.
- Permissible temperature of the medium being handled is +5 to +80°C.
- The pump should not operate against a closed system.
- The pump is limited against which pressure / vacuum it can start running. The ideal conditions are when the pump can start at atmospheric conditions as then the priming is guaranteed.

6 Pump and Controls

6.1 Pump

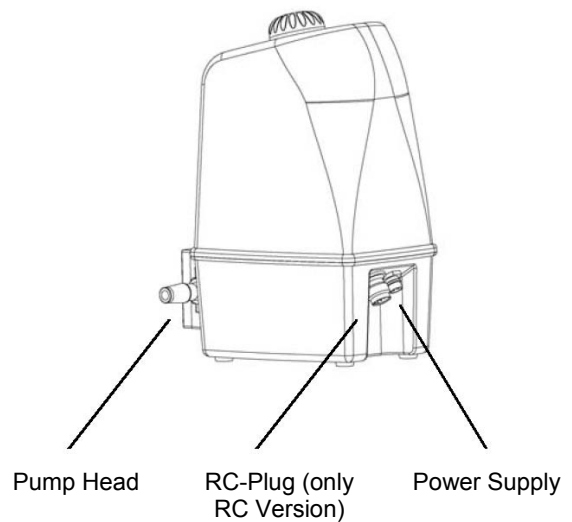

6.2 Controls

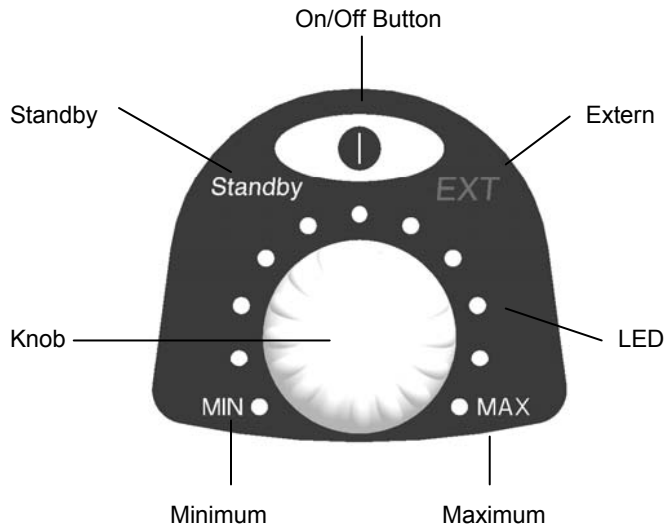

<u>Position</u>	<u>Description</u>	<u>Function</u>
1	ON/OFF Button	Turns the pump on and off
2	EXT	Lights up when analog signal is being used (RC-Version)
3	MAX	Maximum flow
4	Knob	Adjusts the flow from 10% to 100%
5	MIN	Minimum flow
6	LED	Indicates the flow rate
7	Standby	"Standby" lights up green, as soon as the pump is plugged in. Pump is not running.

7 Installation

7.1 Installation

Refer to the points in Section 5.

7.2 Installing the LIQUIPORT®

- The pump is delivered ready to use.
- ❶ Connect the 1/4" Teflon tubing.
- ❷ Plug the adaptor in. The Standby lights up green.

7.3 Operation

- ❶ Select the flow rate
 - Note: If the system should prime fast then select the highest possible flow rate.
- ❷ Start the priming/pumping by pressing the ON/OFF button (STANDBY goes off).
- ❸ Adjust the flow by turning the knob.

7.4 Removing the Pump

- ❶ After using the pump rinse the pump and system with a neutral liquid and then pump it empty.
- ❷ Remove the adaptor from the plug.

8 Error Messages

8.1 Possible LED Error Messages

In order to cancel the error message press the On/Off button.

Error No 1:

LED's blink, Standby symbol lights up. Pump turns off after 5 seconds.

Cause:

Pump was running against pressures over the allowed limit.

Solving the Problem:

- ❶ Reduce the pressure.
- ❷ Change the flow rate.

→ If the cause of error No 1 is not removed within 5 seconds, then the pump goes to error No 2.

Error No 2:

All LED's blink, Standby symbol lights up. Pump turns off.

Cause:

Pump was running against pressures over the allowed limit.

Solving the Problem:

- ❶ Reduce the pressure.
- ❷ Change the flow rate.
- ❸ Start the pump.

9 Troubleshooting

Before working on the pump, ensure the power supply is isolated.

➔ Motor Fails To Start

- Pump is not connected to power supply.
- Power supply is switched off.
- The pressure in the delivery line from the pump is too high.
- Pump is on "STANDBY" → ON-/OFF button not pressed.
- External controlling is connected without input signal.

➔ Pump Not Sucking Liquid In

- Suction side of pump is not connected.
- Liquid level in container is too low.
- Hose connections are leaking.
- A system valve is closed, or blocked.
- The pump head is filled with gas. The gas pressure after the pump can not be overcome because of its compressibility in the working chamber.
- Diaphragm and/or valves are worn out or dirty.

➔ Flow Rate, Suction Height, or Pressure Height Is Insufficient.

- The periphery installation contains components (hoses, valves, filters, etc...) which create too much resistance.
- Hose connectors are not tight.
- Diaphragm or valves are worn out or are covered in dirt.

10 Technical Data

10.1 LIQUIPORT®

Flow Rate ¹ (L/min)	0.5 to 3
MAX Suction (ft H ₂ O)	10
MAX Pressure Head (PSIG)	14.7
Pump Weight ² (gram)	1,500
MAX Ambient Temp (°C)	+5 to +40
MAX Temp of Liquid (°C)	+5 to +80
MAX Viscosity of Liquid (cSt)	150
Head Material	Polypropylene
Diaphragm Material	PTFE
Valves	FFPM
Protection Type	IP65
Protection Class	III

¹ Measured with water at 20°C and pressure 0mWg.

² The weight can vary depending on the individual version.

10.2 CE-Marking

The LIQUIPORT®-Diaphragm liquid pumps are in accordance with the following standards:

- EN 61010 – 1
- EN 60529
- EN 61326 – 1
- EN 55022
- EN 61000-4-6
- EN 61000-4-3
- EN 61000-4-4
- EN 61000-4-2
- EN 61000-4-5
- EN 61000-4-11
- EN 61000-3-2
- EN 61000-3-3

11 Exploded View

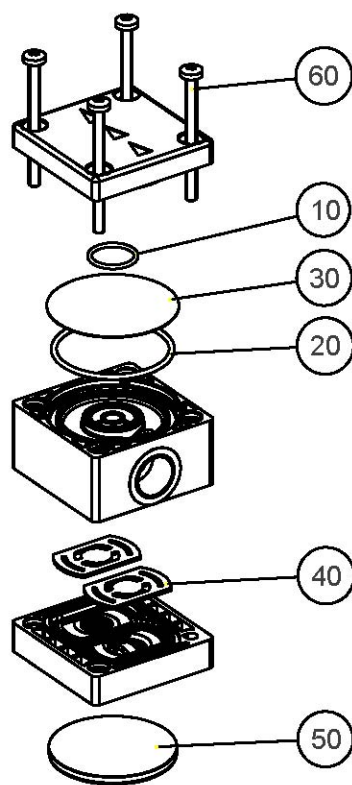

<u>Position</u>	<u>Description</u>
10	O-Ring
20	O-Ring
30	Resonating Diaphragm
40	Valve Plate
50	Diaphragm
60	Head Screws

11.1 Spare Parts List

<u>Position</u>	<u>Description</u>	<u>Order Number</u>	<u>Quantity Per Pump Head</u>
60	Head Screws	019 698	4
30	Resonating Diaphragm, PTFE	068 513	1
20	O-Ring 40 OD, PTFE	019 752	1
40	Valve Plate, FFPM	068 903	2
50	Diaphragm, PTFE	068 595	1
10	O-Ring 15 OD, EPDM	008 112	1
---	Spares Kit, Polypropylene	068 691	1

1. This list contains the number of parts required per pump head.
2. The listed parts can also be ordered separately.

12 Return Requests/Inquiries

Direct all warranty and repair requests to CHEMGLASS Technical Service for instructions before returning any unit for repair or evaluation. We will send you a "Return Instruction Sheet" for guidance on the proper marking, packing and documentation requirements. Important information conforming to the "Right To Know" act, such as a Material Safety Data Sheet may be required.

Products shipped to CHEMGLASS must have a Return Authorization Number (RA#) marked on the outside of the package. Otherwise the shipment will be refused by our receiving department. Please contact CHEMGLASS Customer Service for RA#.

For service or parts, contact:

Chemglass, Inc

3800 North Mill Road

Vineland, NJ 08360

US and Canada

Phone: 1-800-843-1794

Fax: 1-800-922-4361

customer-service@chemglass.com

www.chemglass.com