

CG-1949 Benchtop Support Stand Instruction Sheet

Each Kit Contains The Following:

#	Qty	Description
A	1	Flask/Reactor Support Frame with Single Reactor Base Plate
B	2	S.S. Uprights
C	2	Crossbar For Reactor/Motor Support
D	2	Reactor Support Rod For 1000mL To 5L
E	1	Reactor Support Rod For 250mL To 1000mL, Velcro
F	1	60mm ID Cork Ring, Fits 250mL Reactor
G	1	90mm ID Cork Ring, Fits 300mL To 1000mL, Reactor
H	1	120mm ID Cork Ring, Fits 2L To 5L Reactor
I	1	250mL Adapter Plate
J	1	300mL Thru 1000mL Adapter Plate

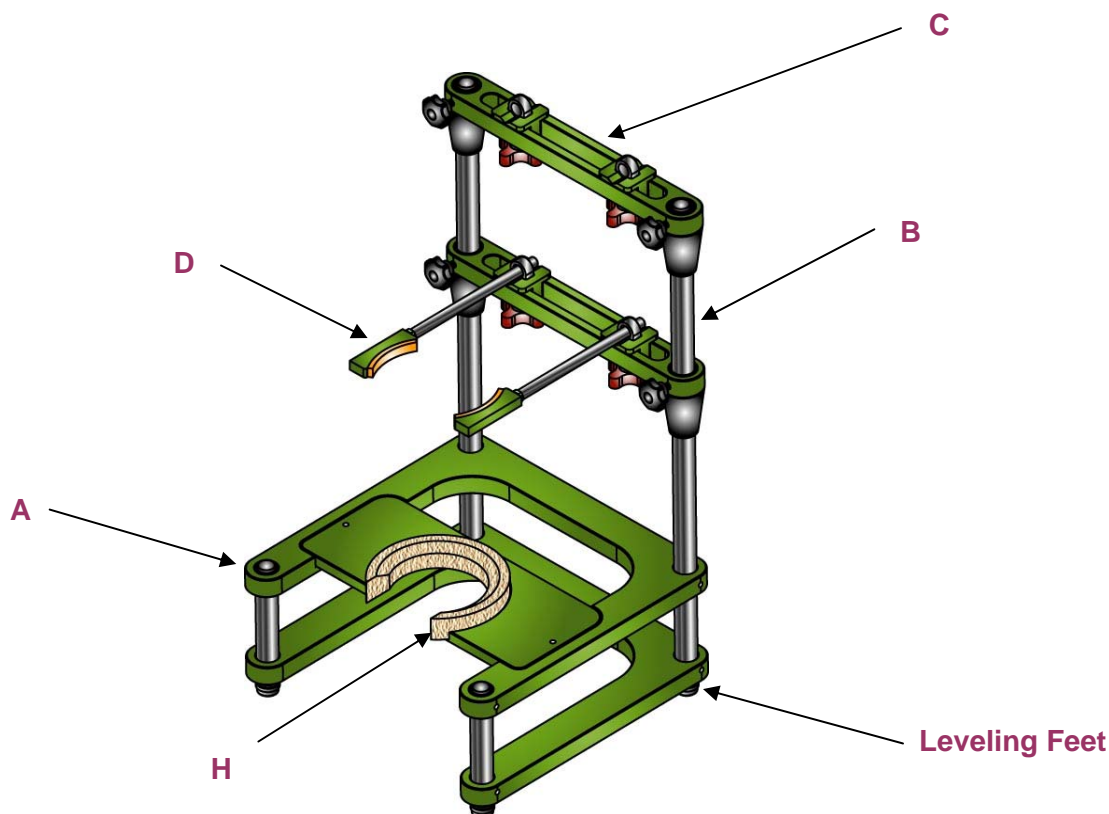

Assembly Instructions:

1. With the stand **A** in the upright position, install the uprights **B** by sliding the S.S. pipe through the top of the fittings in the base. Tighten the allen screws. Note: Leveling feet will be at the bottom and are adjustable.
2. Slide both crossbars **C** over the uprights and position as shown on the diagram. The red knobs should be on the bottom. Tighten the black knobs on each end to hold them in place. The positions will have to be adjusted depending on the glassware and motor used in the support stand.
3. Install the support rod(s) **D** or **E**, cork ring **F**, **G**, or **H** and adapter plate **I** or **J** that corresponds with the reactor size that you are using.